

# SCCZ-1



Continuous  
Conditioning  
System  
**SCCZ-1**

**ZACCARIA**

# SCCZ-1

## Continuous Conditioning System SCCZ-1

The Continuous Conditioning System, model SCCZ-1, has by purpose to modify the initial moisture of the cereal, assured an uniform water absorption in less time, and prepare the grains for the next process.

In the specific case of corn grains for the semi-humid degermination process, the water should reach the germ and the hull, however this process does not increase the moisture in the kernels of corn. The SCCZ-1 has a control system which is responsible for water flow and rotor spinning. This way the corn inside the conditioning can be homogenized by water volume and time. Besides, the SCCZ-1 has a paddle angle adjust. The inclination position is responsible for the best homogenization of the product in process.

### Model:

SCCZ-1

### Power / poles:

Main motor  
1,1 kW / IV  
1,5 hp / IV

### Capacity: Inlet maize (kg/h):

600 to 900

### Water outflow (l/h):

To 50

### Approx. shipping volume (m<sup>3</sup>):

1,5

### Approx. shipping weight (kg):

196

### SCCZ-1 ADVANTAGES

- Continuous system;
- Higher improvement into the degermination;
- Uniform grain homogenization;
- Less conditioning time.

### FEATURES

- Stainless steel construction;
- Gear box assembled directly in the axle;
- Control Panel with feeding adjustment through of the frequency inverter and adding water by rotameter (optional);
- Opening in the rear part of the equipment for cleaning;
- Superior cover in acrylic easily removed for cleaning, allowed good visualization of the product.



Assembled example:  
SCCZ-1 with the DHZ-2 Degermer.

- The machine is originally supplied without motor.

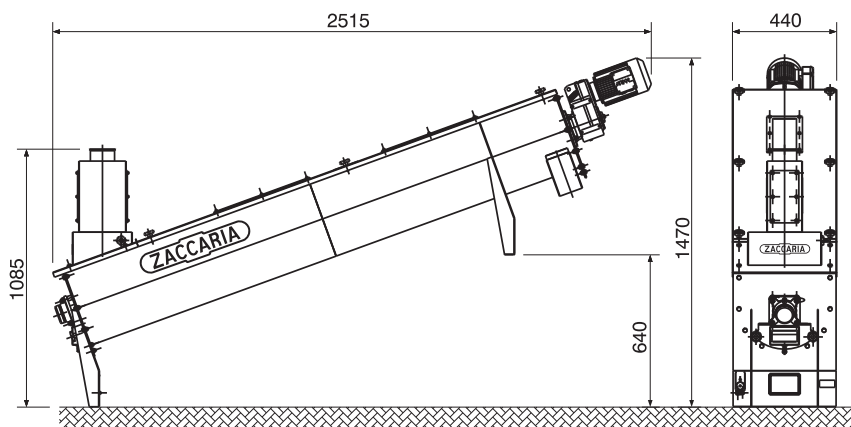

# ZACCARIA

OUR EXPERIENCE MAKES THE DIFFERENCE

INDÚSTRIAS MACHINA ZACCARIA S/A

Rua Laranjal, 180  
CEP: 13484-016 - Limeira - SP - Brasil  
Phone: (55.19) 3404-5725  
Fax: (55.19) 3404-5720

[www.zaccaria.com.br](http://www.zaccaria.com.br)  
[comex@zaccaria.com.br](mailto:comex@zaccaria.com.br)



Indústrias Machina Zaccaria S/A reserves the right to change the information stated in this catalogue, including the color and other details of the machine, without previous notice.